

REVISIONS		ZONE	LTR	DESCRIPTION	DATE	APPD
G	14			A REVISED PER 0720-0230-93	2/28/94	CAP

METRIC
DIMENSIONS LISTED IN mm [INCHES]

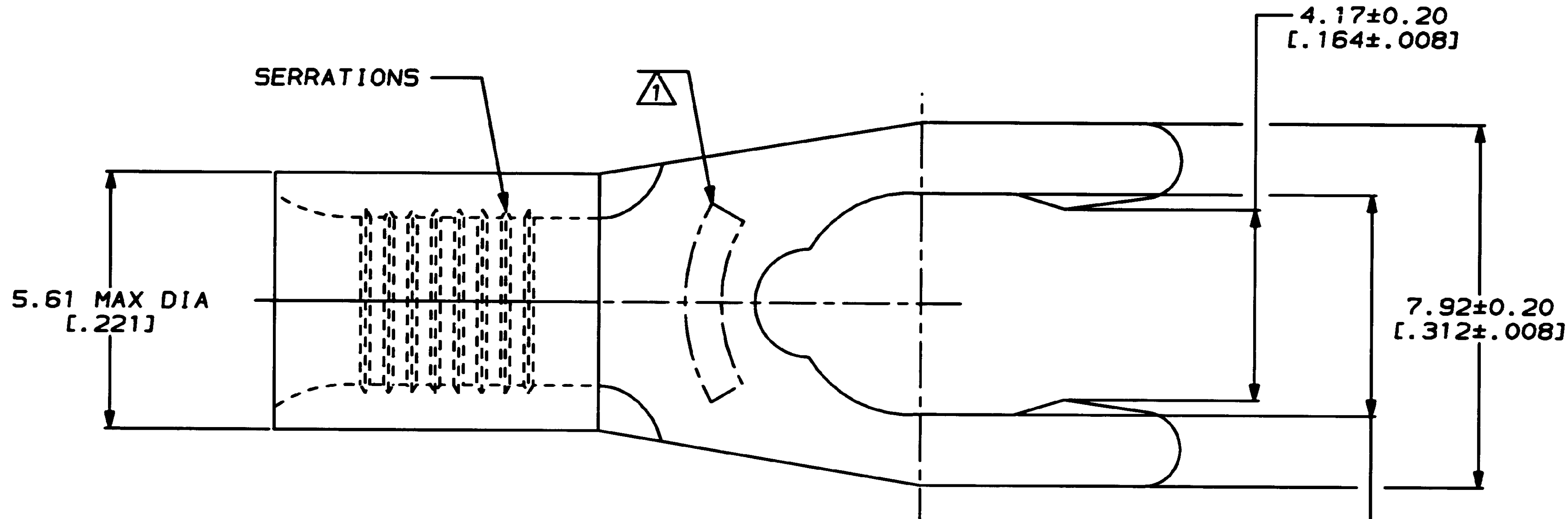

AMP WIRE RANGE	E13288 Listed
12-10 AWG STRANDED	12-10 AWG STRANDED
LR7189 Certified	MILITARY P/N AND CLASS
NOT CERTIFIED	NOT APPLICABLE

STAMP 10S AMP 12-10* APPROX AS SHOWN
10S INDICATES STUD SIZE

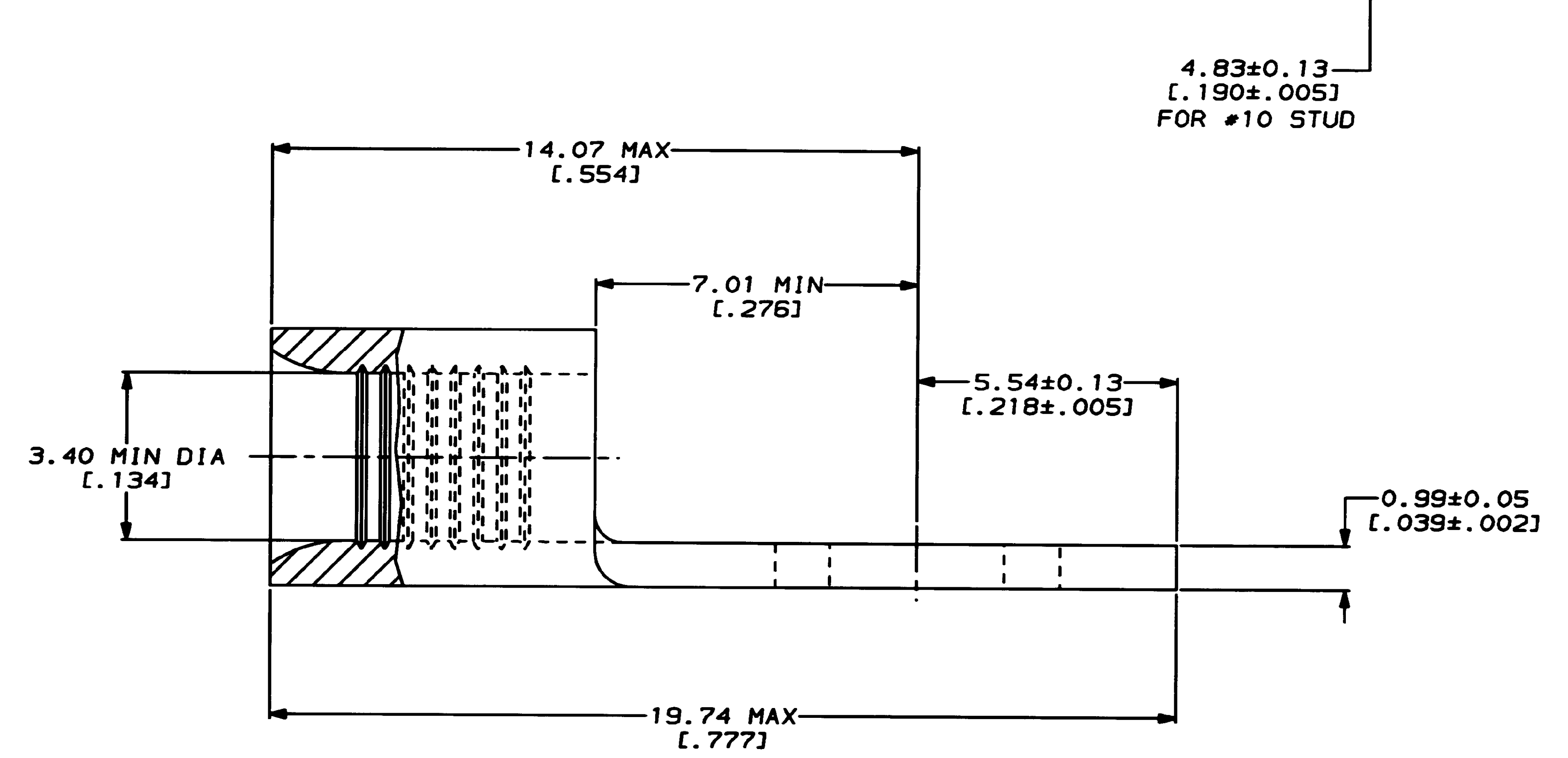

AMP INCORPORATED CUSTOMER SERVICE SYSTEMS		MAX RECOMMENDED OPERATING TEMPERATURE: 170°C MAX		DO NOT SCALE PRINT. UNLESS SPECIFIED DIMENSIONS IN mm [INCHES] TOLERANCES ON: 2 PLC DEC ± - 3 PLC DEC ± - ANGLES ± -		DR 2-12-93 TA BRINKMAN		53274-2 PART NO	
FOR ADDITIONAL PRODUCT INFORMATION OR COPIES OF DRAWINGS AND TECHNICAL DOCUMENTS	PRODUCT INFORMATION CENTER 1-800-522-6752	VOLTAGE RATING: NOT APPLICABLE		MATERIAL PHOSPHOR BRONZE PER ASTM B-103 ANNEALED		CHK 2-12-93 DA PATTERSON		AMP AMP Incorporated Harrisburg, PA 17105-3608	
FOR APPLICATION TOOLING INFORMATION	TOOLING ASSISTANCE CENTER 1-800-722-1111	WIRE CROSS SECTIONAL AREA RANGE: 2.62-6.64mm ² [5,180-13,100] CIR MILS STRANDED		FINISH TIN PLATE 0.00254 [.000100] MIN THK PER MIL-T-10727		APPD 2-12-93 DE MILLER		NAME TERMINAL, SHORT SPRING SPADE, BUDGET	
FOR ORDER ENTRY	1-800-526-5142	THIS DRAWING IS A CONTROLLED DOCUMENT FOR AMP INCORPORATED. IT IS SUBJECT TO CHANGES AND THE CONTROLLING ENGINEERING ORGANIZATION SHOULD BE CONTACTED FOR THE LATEST REVISION.		APPLICATION SPEC -		APPD 2-12-93 JL MECKLEY		SIZE C 00779 C-53274	
				WEIGHT -		PRODUCT SPEC -		DRAWING NO C-53274	
						SCALE 10:1		SHEET 1 OF 1	